

星辉数控 EXCITECH



领先·创新——专注家具产业智慧化生产

自动化解决方案

- 智能信息化工厂生产解决方案
- 板式家具生产解决方案
- 智慧包装生产解决方案
- 橱柜门板生产解决方案
- 实木生产解决方案
- 五轴联动加工(先进材料)生产解决方案
- 雕刻设备生产解决方案
- 软件应用方案

Global Business Development

North Base: No.1832 GangYuanQi Road, High-Tech District,
Jinan, Shandong Province, P.R.China

South Base: No.4 KeJiZhong Road, High-Tech District, Zhaoqing,
Guangdong Province, P.R.China

E-mail: global@sh-cnc.com

Website: www.excitechcnc.com

WhatsApp: +86 186 5313 1750 Mobile: +86 186 5319 8309

北方基地: 山东省济南市高新区港源七路1832号

南方基地: 广东省肇庆市国家高新区科技大街中4号

电话: 400-800-5937

网址: www.sh-cnc.com

VER2024.08



关注公众号



抖音视频号



Contact Us



We Are EXCITECH®

EXCITECH® 星辉数控是一家专注于自动化木工数控设备研发、制造及生产软件开发和应用的企业，北方基地位于济南国家级高新开发区，华南生产基地位于广东肇庆大旺国家高新区，是高新技术企业。

- ◆ 我们专注于打造家具产业智能工厂，产品涵盖板式家具生产线设备、裁纸机、数控开料机、数控裁板锯、激光封边机系列、数控排钻加工中心系列、镗铣加工中心系列、全系列五轴立体化加工中心、不同规格型号的加工中心和雕刻机等机械设备，广泛应用于板式家具、定制橱柜衣柜、五轴三维立体化加工、实木家具等非金属数控加工领域。
- ◆ 我们是国内率先能够进行专业智能工厂整厂规划并提供相关成套设备及软件的厂家，全球上百套成熟落地案例，我们的数控开料设备、全自动封边机、高速排钻加工中心及包装线系列产品，结合自动化软件的定制家具柔性加工生产线，能够真正为您量身打造板式橱柜衣柜生产的一揽子解决方案，将定制化纳入规模化生产。
- ◆ 我们的质量标准定位与欧美同步，全线产品标配国际品牌零部件，是国内少数采用数控加工设备加工全部机械零部件的厂家，配合先进的加工和装配工艺，并有严格的过程质检把关，致力为用户提供长期工业化使用下稳定可靠的设备，产品已出口100多个国家和地区。
- ◆ 我们的技术能帮助您以更简单的方式、用更低的投入以及更少的时间，将理念和设计迅速转化为产品，提高您的工业自动化水平，摆脱对技术工人的依赖，有效地提高管理效益和生产效益。

真诚的欢迎您来公司实地考察参观，我们的理念和品质您可亲眼见证！



山东济南北方生产基地



广东肇庆南方生产基地

专注品质、注重服务、全心全意为用户创造价值

Honors 企业荣誉 截至到2024年初统计

<p>49项</p> <p>国家认定的荣誉及奖项 National Awards</p> 	<p>40项</p> <p>软件著作权 Software Copyright</p> 	<p>160项</p> <p>发明及实用新型专利 Invention and Awards</p> 
--	--	---

定制家具生产线科技鉴定为“国内领先水平”
公司荣获“高新技术企业”
山东省专精特新企业
第一批“高端装备制造创新型企业”
“山东省工程技术研究中心”
“山东省科技进步一等奖”
.....



了解更多

Partners 合作伙伴 我们还有更多合作伙伴，期待您的加入！

				
				
				
				
				
				
				
				

声明：以上排名不分先后，客户名称及商标所有权归客户所有，不做任何其他用途！

数控排钻单元 Drilling Cell

单双工位两机连线

产能: 3400-3800片/8小时
Output: 3400-3800 pcs /8hr

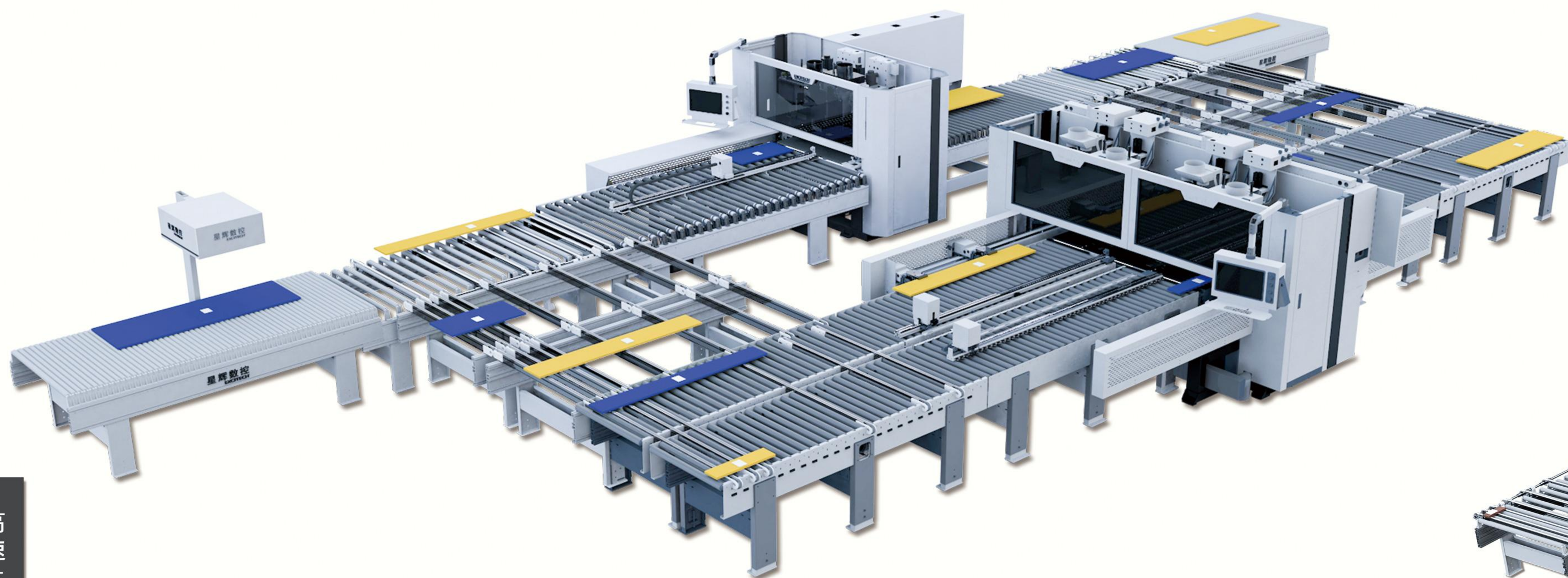

单工位三机连线

产能: 3000-4000片/8小时
Output: 3400-3800 pcs /8hr

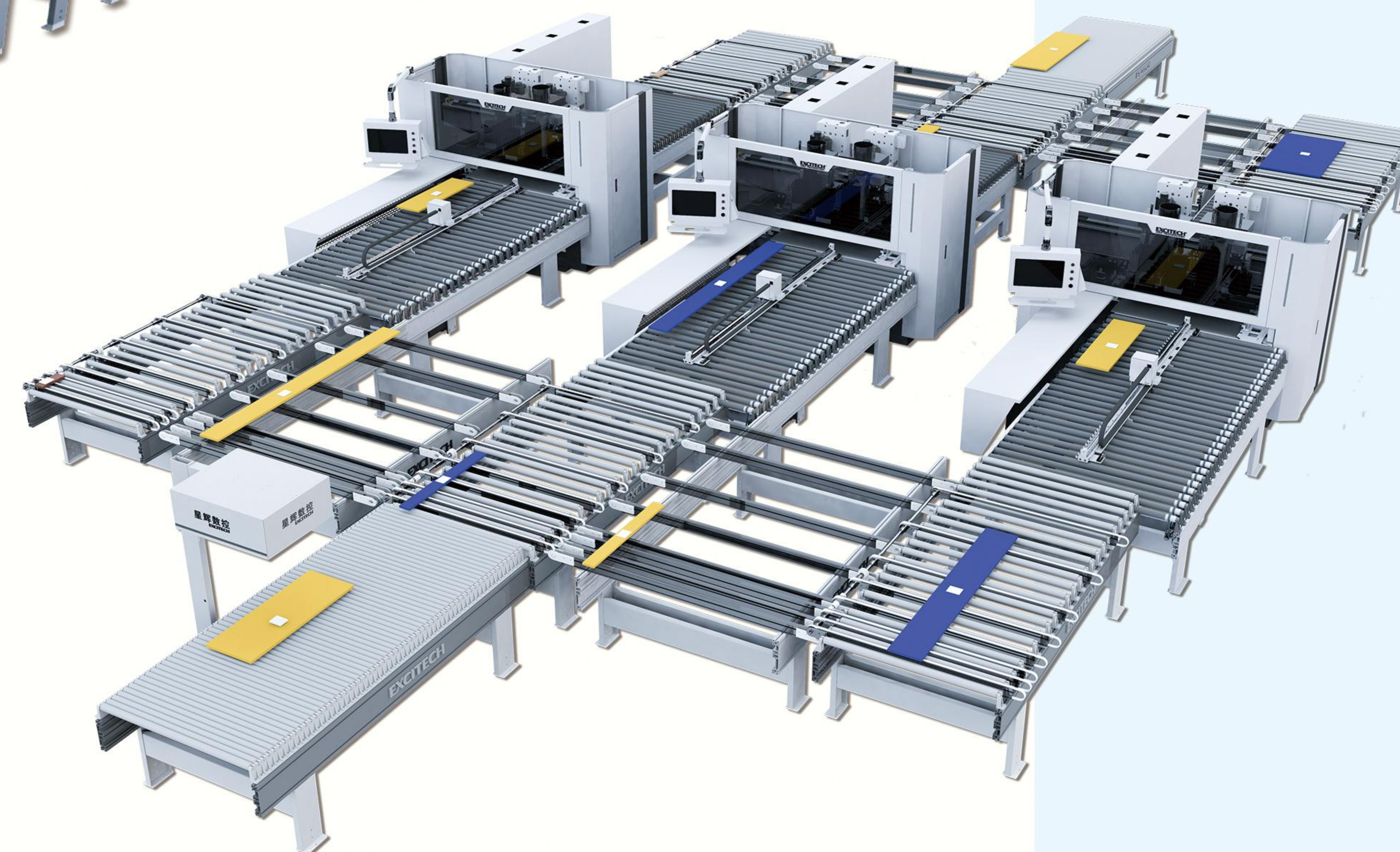

高速六面钻

高速六面钻



扫描二维码
了解更多详情

根据客户产能、工艺需求，自由组合搭配连线方式与数量

Available in different scenarios for your specific needs



双工位六面钻加工中心

EHS-2T Double Work Zone 6-sided Drilling Machine



双工位结构 Double Work Zone



一个工位加工时，另外一个工位执行上下料，不间断生产
Work carried out on one table while the other loads and unloads

- | | |
|---------------------------|--|
| 双工位
Double Work Zone | 不间断加工，大幅提高生产效率
Processing without interrupting the work cycle, greatly enhances efficiency |
| 节约空间
Smaller Footprint | 结构紧凑，占地面积小
Same output delivered, only half of the space |
| 小板加工
Highlight | 最小可加工板件宽度手动进料为30mm，自动进料为50mm
Ability to process board as small as 30mm when manually infeed and 50mm when automatically |

钻包结构 Double Work Zone



底部双钻包，每个钻包含9个垂直钻+顶板
Two Bottom drill banks both with 9 vertical drills

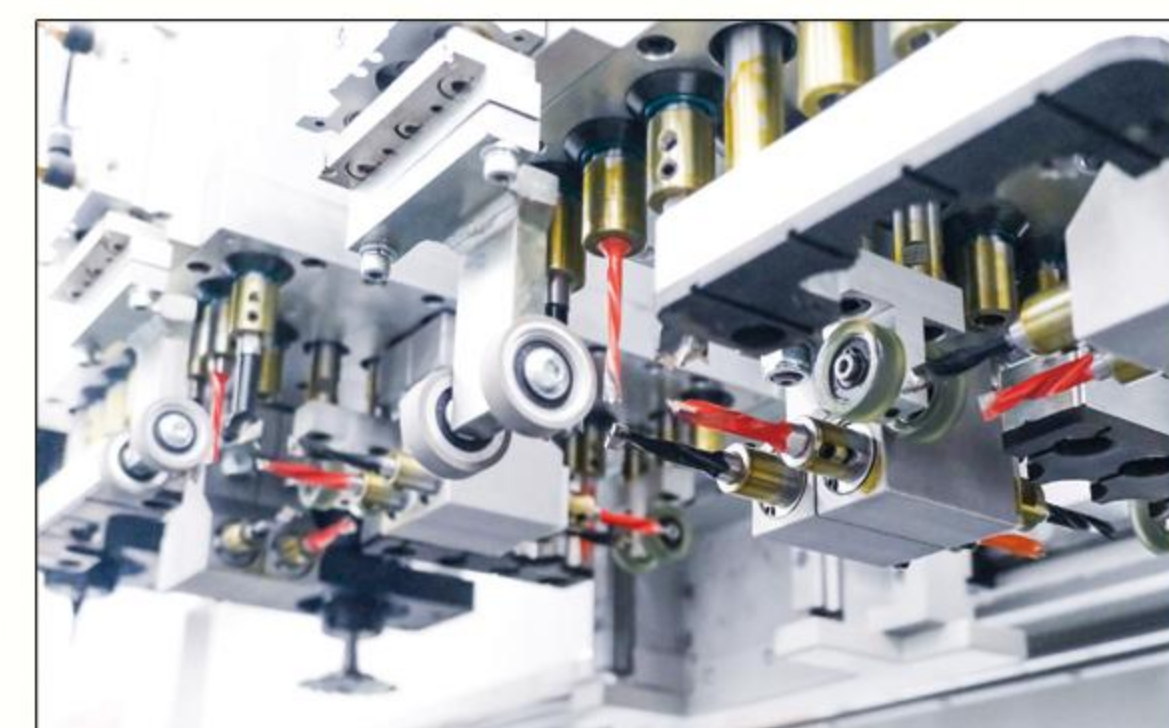

可选自动换刀功能
Auto tool changer optional

双工位通过式六面钻加工中心

可选4钻包或6钻包
4 drill banks or 6 drill banks optional

EHSA-2T Double Work Zone Throughfeed 6-sided Drilling Machine



可选六钻包
Six Drilling Banks Optional

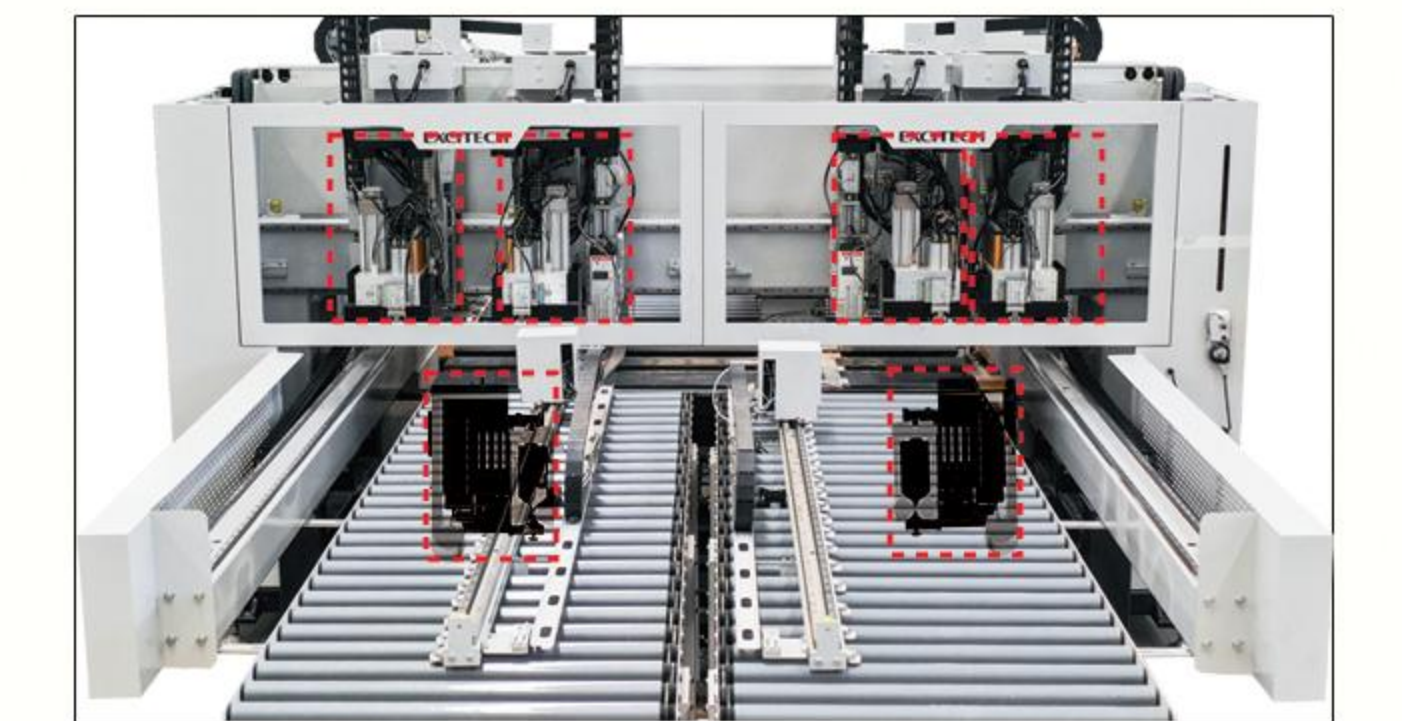

六钻包可进一步提高加工效率
Six drilling banks, greater efficiency

独有优势 Unique Advantage

大小板件智慧分配，加工前无需人工挑选

≤650mm宽度板材可双工位同时加工
Parts under 650mm can be processed on two tables simultaneously

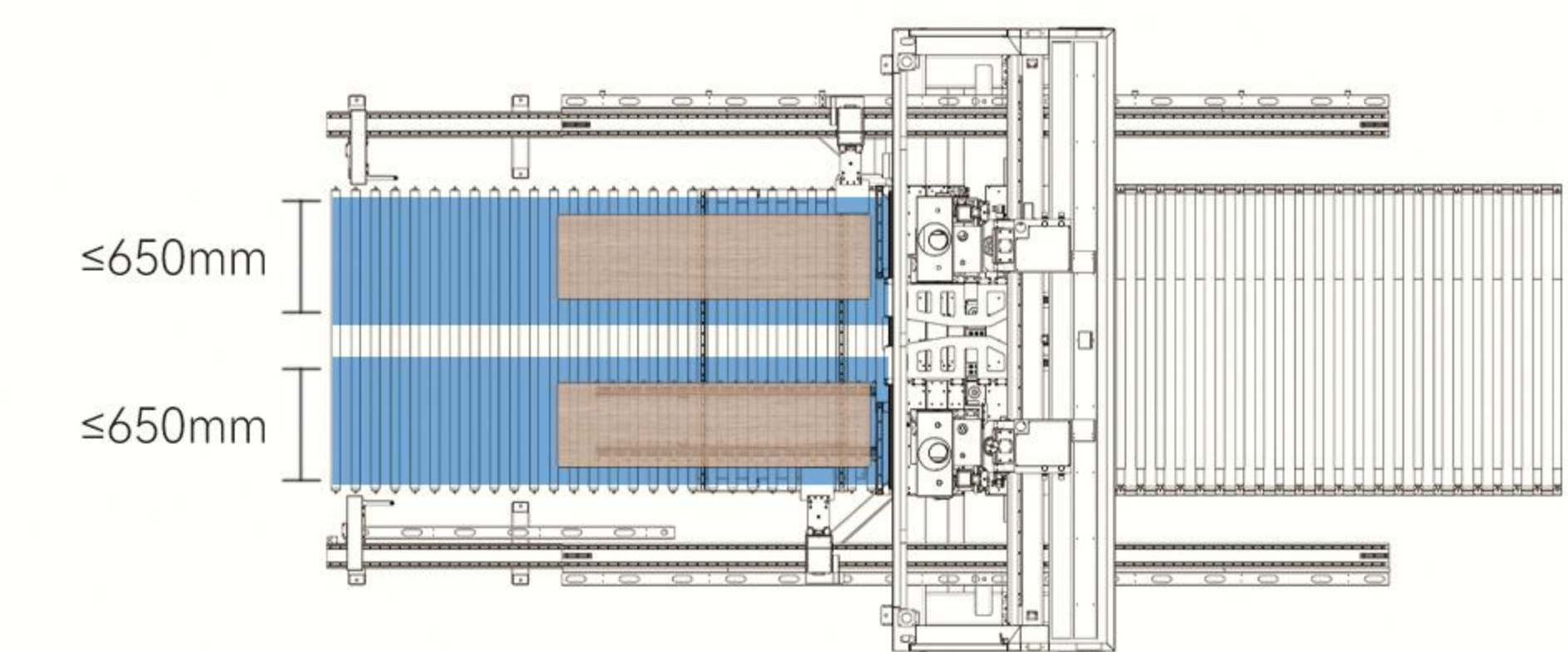

> 650mm宽度板材单工位双钻包加工
Parts above 650mm can be processed with both drill banks on one table

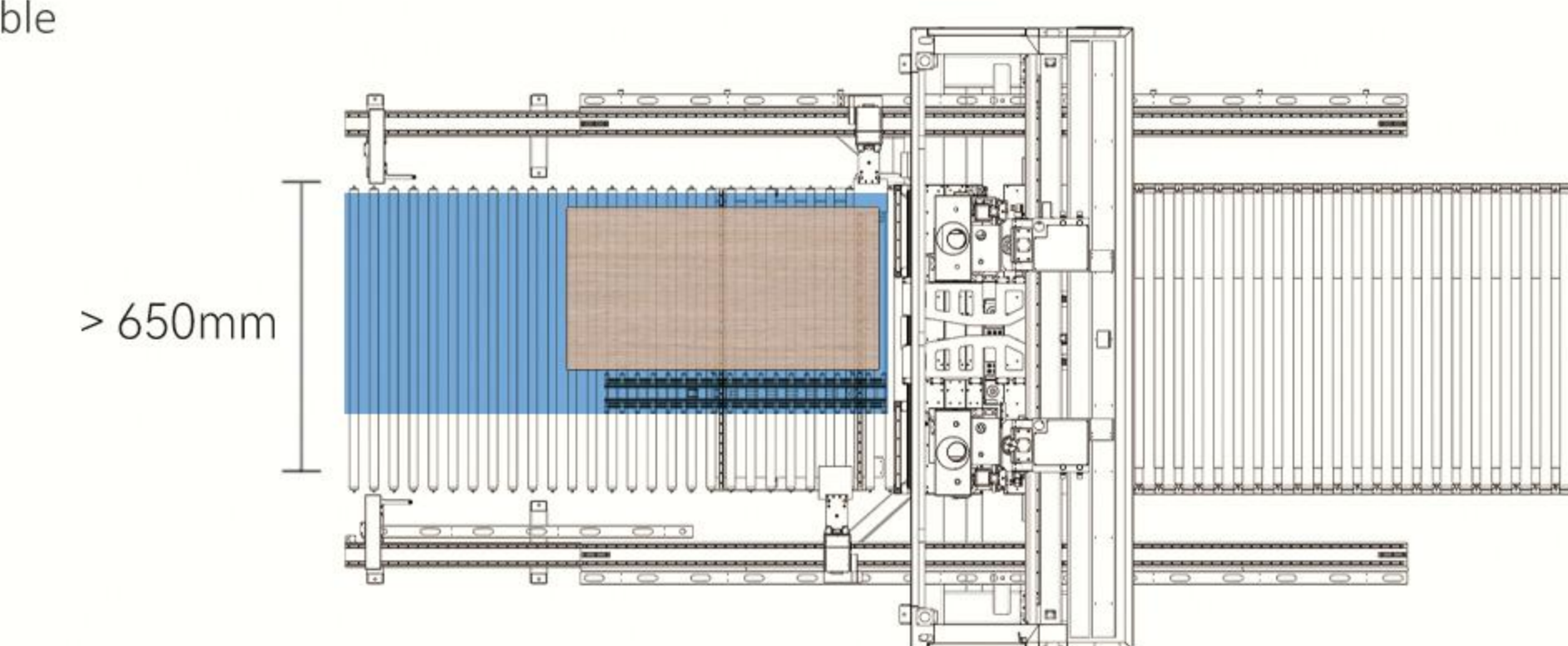

数控全能钻加工中心

All-purpose 6-sided Drilling Machine



扫描二维码
了解更多详情
Scan to learn more

高速六面钻

自动换刀结构

Automatic Tool-change Structure



自动换刀功能
Auto Tool Changers

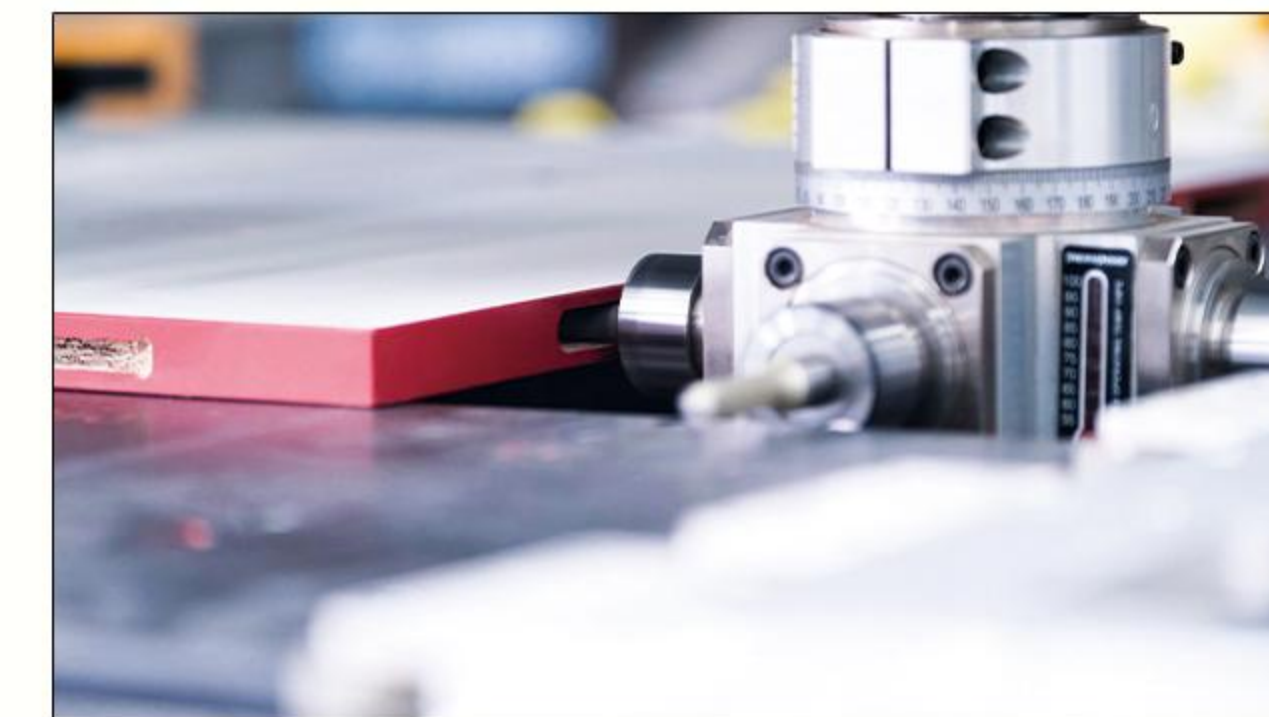

自动换刀带四面侧铣功能
Auto Tool Changers
with all-purpose aggregate



可选360°旋转刀头

实现工艺

Flexible tool changing allows for versatile processing such as lamello and other invisible fittings



拉米诺

灯带槽

拉直器

三合一

天地铰链

木得易

乐扣件

闭门器

合页槽

门锁孔

隐形拉手生产解决方案

Invisible Handle Processing

更符合工艺流程的免拉手解决方案，牛角、火箭、外矩形、内矩形、半圆、内圆、通体、U形拉手一键生产

门墙柜一体生产解决方案

For Complex Processing / Craftwork

可实现灯线槽、收口条、海棠角等多种门墙柜工艺

高定工艺解决方案

For High-end Bespoke Applications

拉米诺、木得易、乐扣、拉直器、天地铰链、压贴门锁、隐形门把手等

高速六面钻

六面钻加工中心 EHS 单钻包六面钻 Single Drill bank
EHSW 双钻包六面钻 Double Drill bank

EHS 6-sided Drilling Machine



特别推荐
了解高速六面钻

气浮台面，有效保护板材表面不被划伤，同时轻松移动板材，降低劳动强度



Air table reduces friction and protects the delicate surface

六面加工
Six Sided Processing

六面打孔操作一次完成，无需二次定位
Six sided drilling completed in one cycle, require no second positioning

一体式床身
Integrated Machine Frame

加工精度保持性更好，落地即生产，无需拆装
High precision throughout service life

小板加工

最小可加工板件宽度为30mm
Ability to process board as small as 30mm

六面钻加工中心

EHS-E 6-sided Drilling Machine

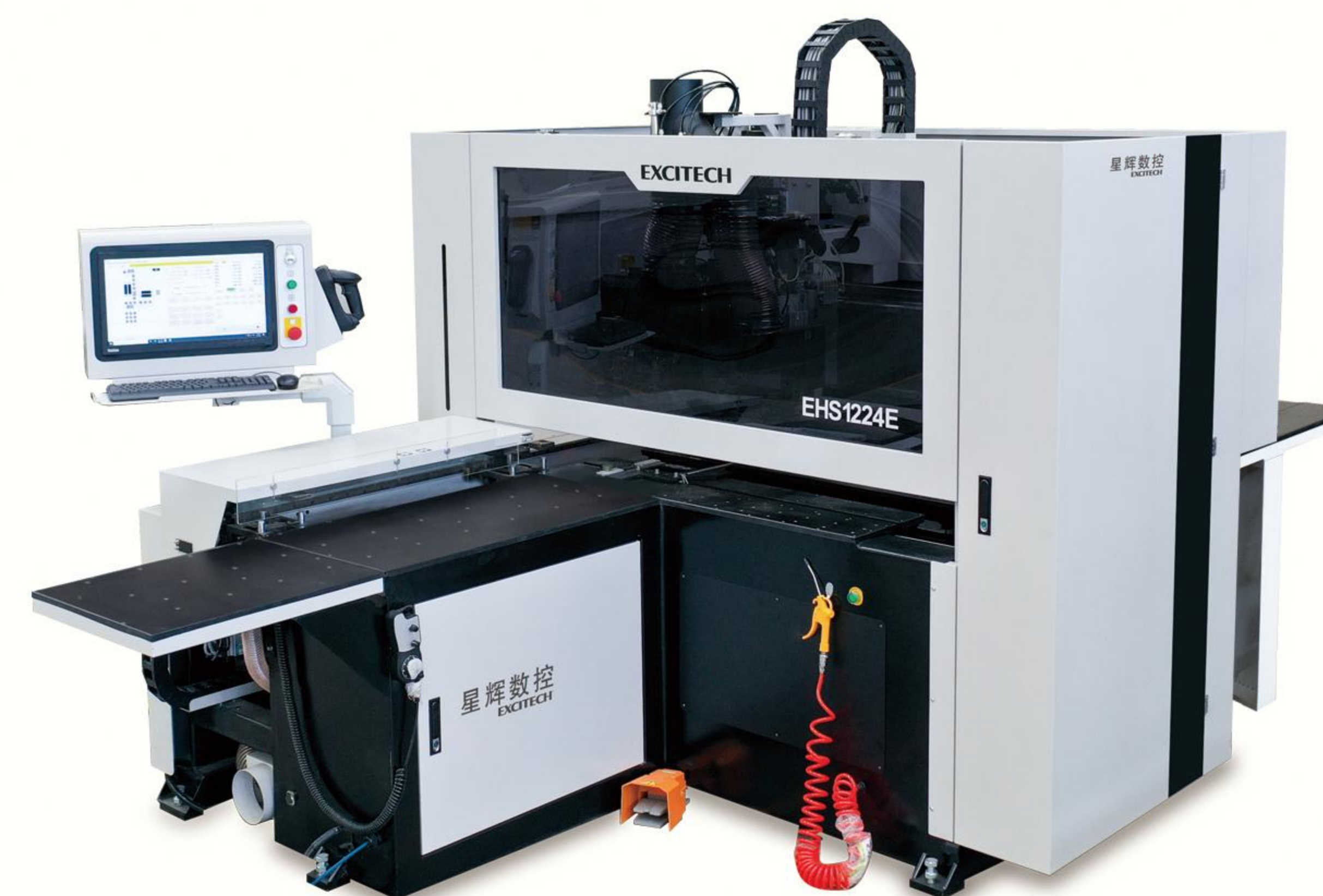

小，成大作

Compact Size, High Throughput

3600x2200mm

最大加工尺寸
Max. Work Size 1200x2800mm

顶部12垂直+8水平+3.5kW主轴
底部9垂直+3.5kW主轴

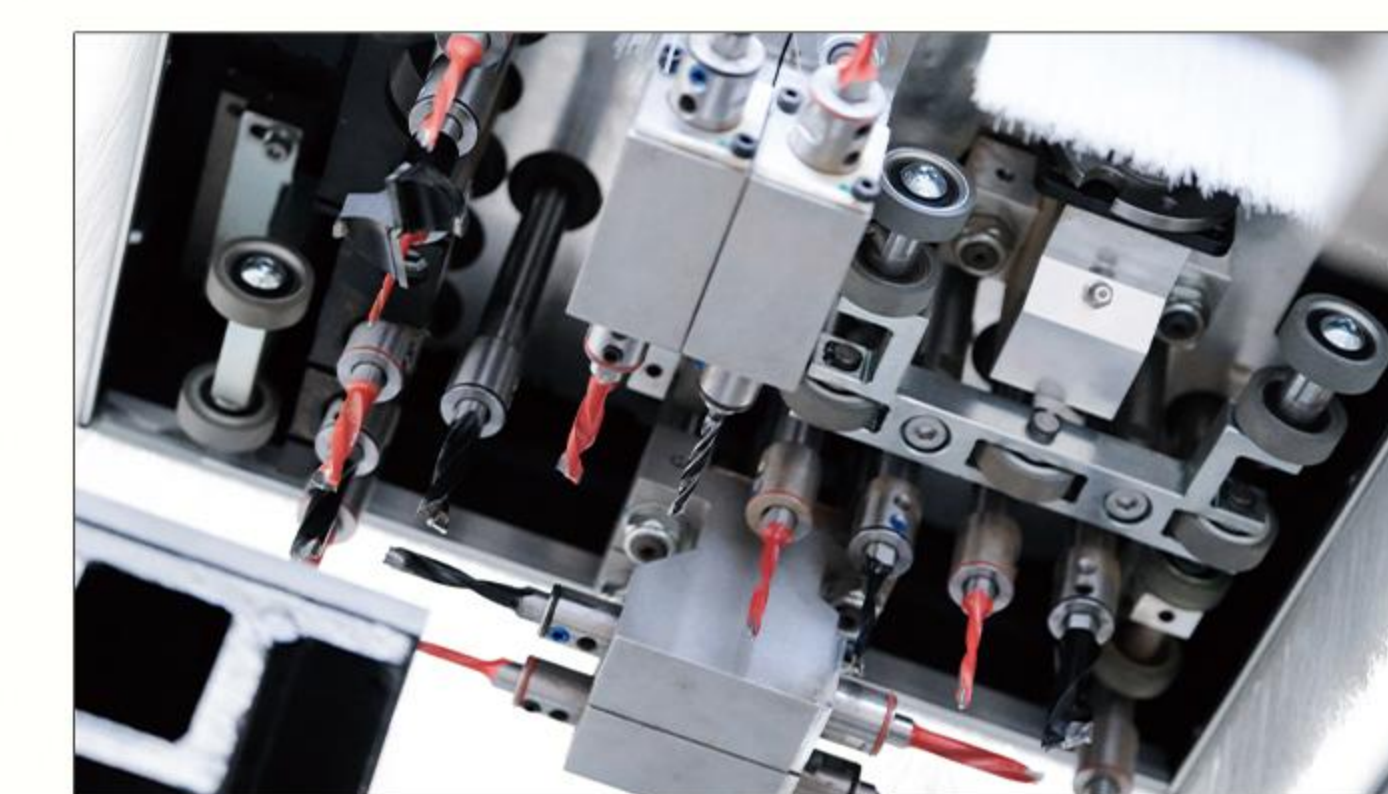

可选自动换刀结构
Auto Tool Changer Optional



独有优势 Unique Advantage

垂直孔间距≥64mm同时启动双钻包，钻包利用率92%+



Holes with a spacing of 64mm are processed with one stroke, featuring high utilization rate of 92% of both drill banks.

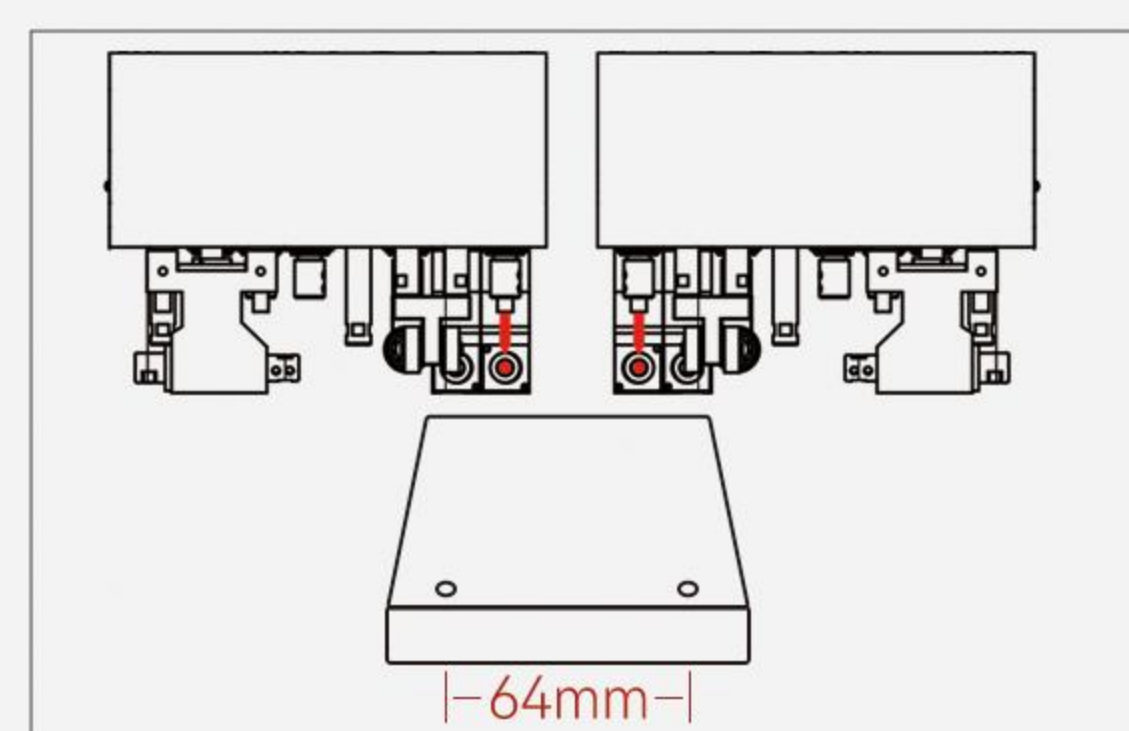

一体式焊接床身，一次加工成型，精度保持性好，落地即生产，无需拆装
Unibody frame—unpack and ready to produce

可选功能 Options



可选双下主轴，提高加工效率的同时，提高拉直器等垂直槽的开槽精度

With the option to upgrade to two spindles on the bottom, this machine is able to work with more efficiency as well as greater grooving precision

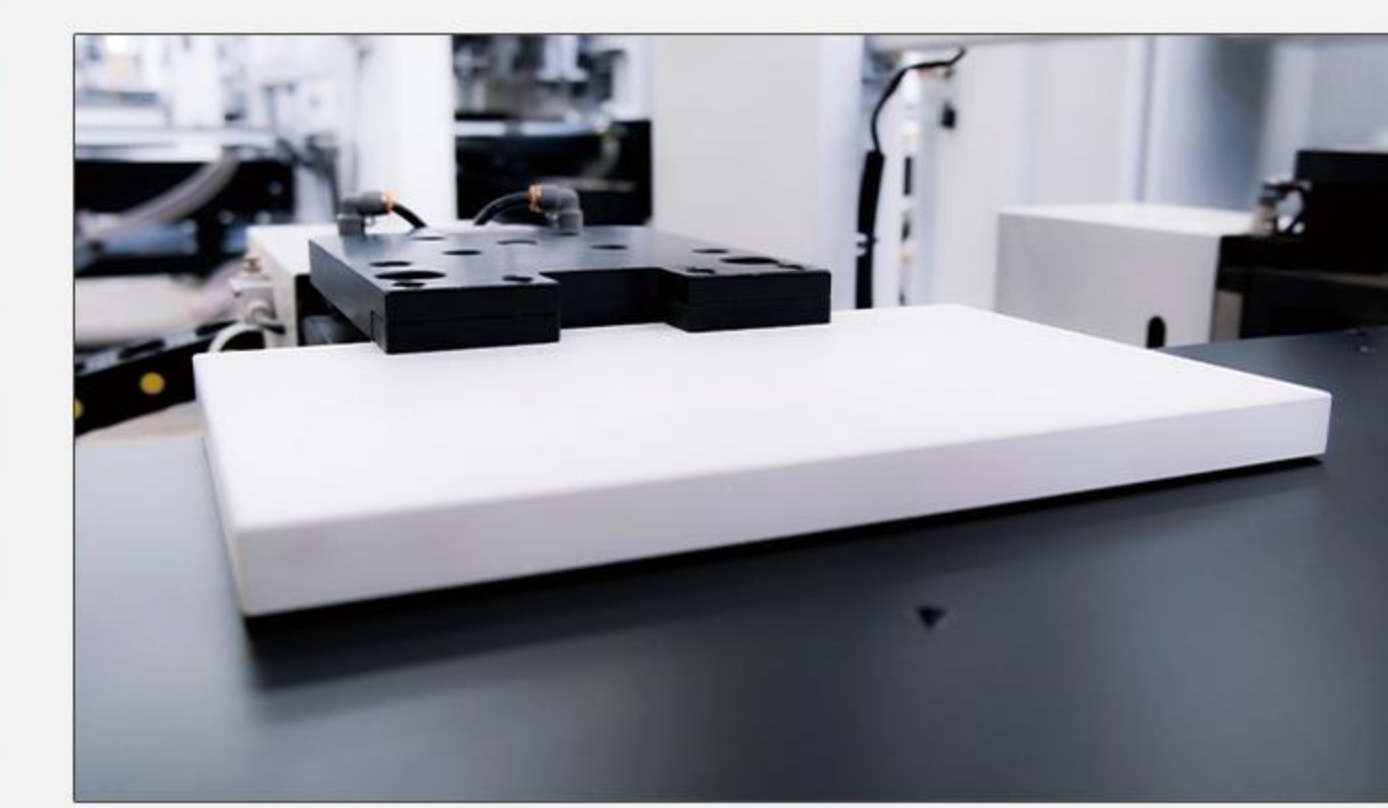

可选气浮抓手，有效避免划伤板材表面

Option to upgrade to air float grippers. More suitable for delicate surfaces

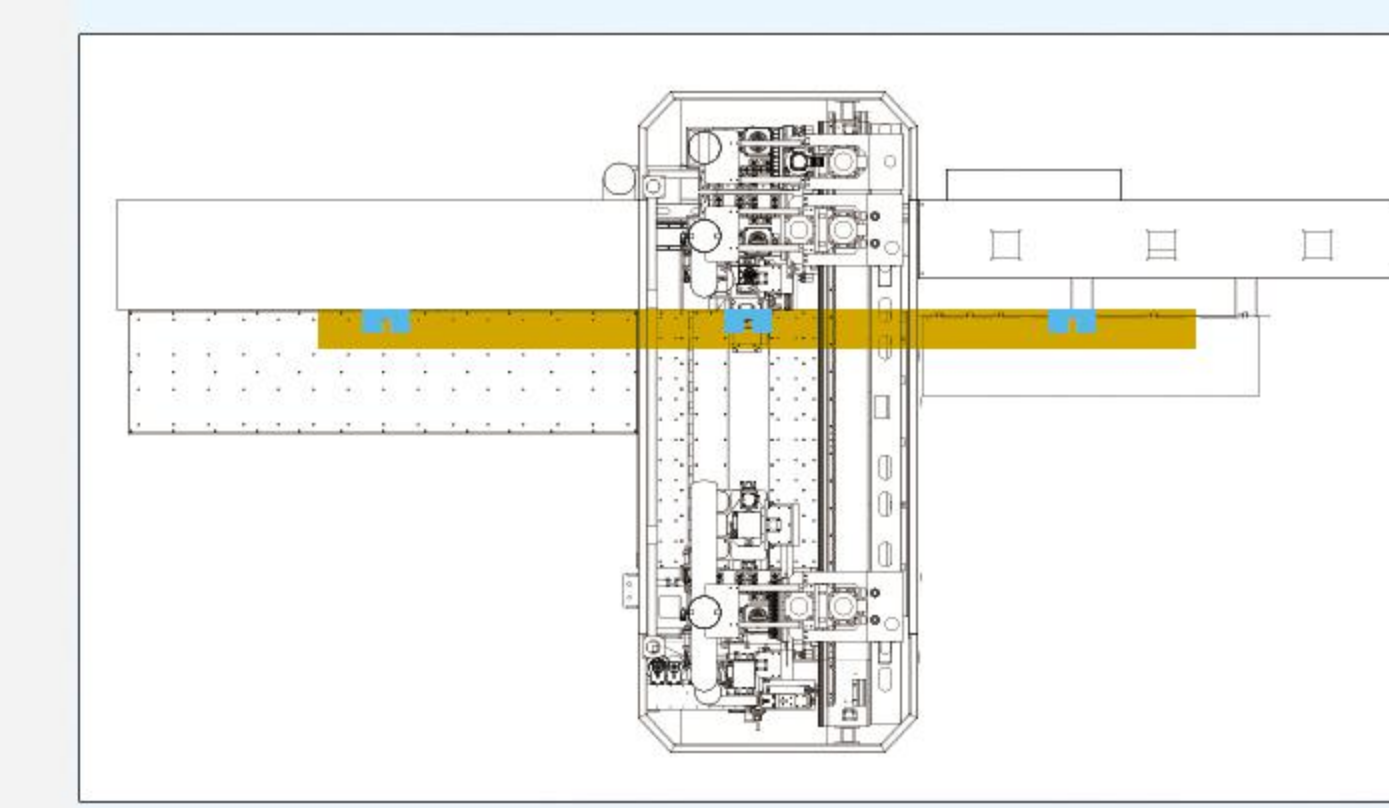

可选三抓手，加工长板件更稳定

Option to upgrade to 3 grippers to deliver better hold for long workpieces

星辉专有优势 软+硬件一体化的全套解决方案

What makes us SPECIAL We supply integrated solutions including softwares



自研CAM优化软件，整机综合效率提升 **35%**

Independently Developed CAM Software
35% Efficiency Bonus Compared to Peer Machines

- 算法提升路劲行程方式，优化避让动作，实现高效加工
Optimized algorithms and dodging movements

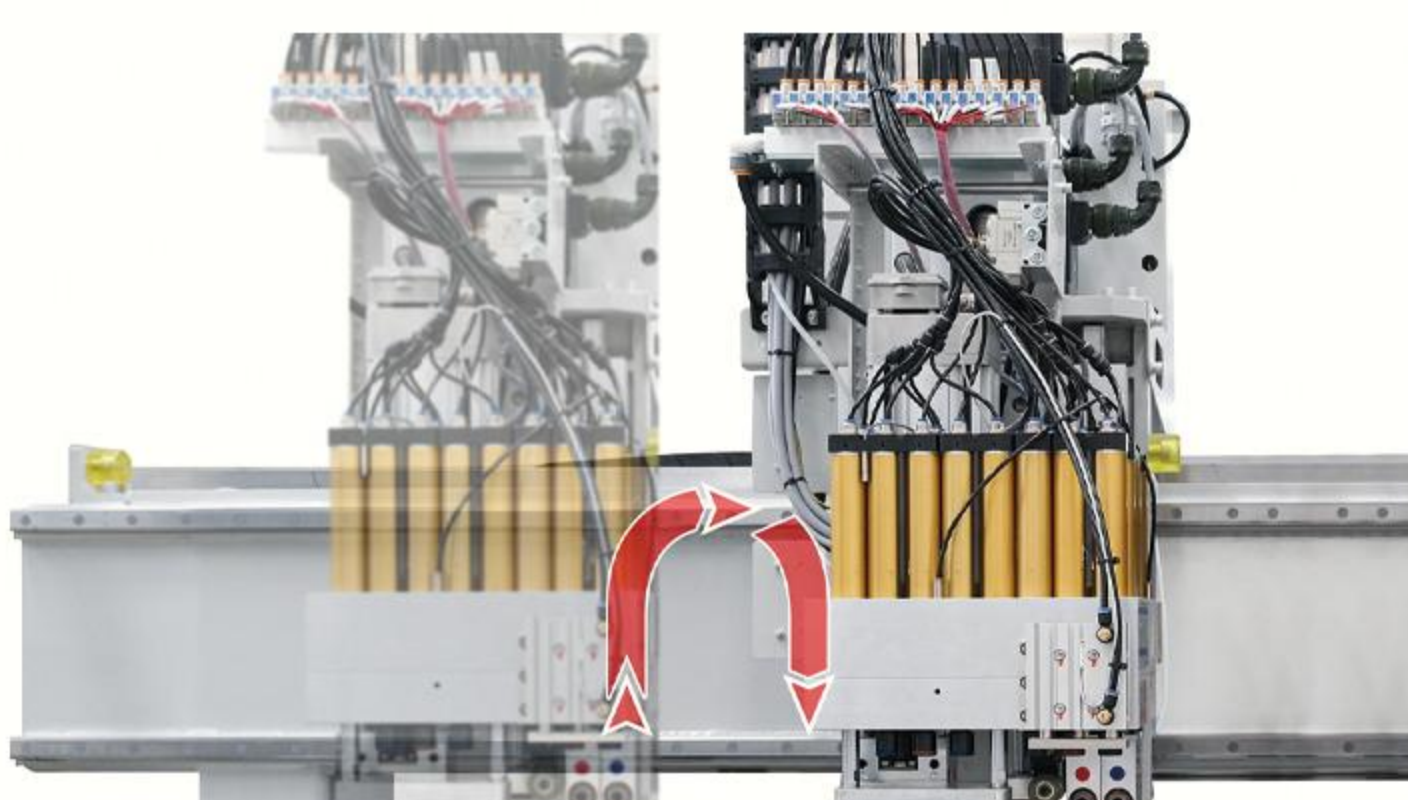

- 为钻孔效率特别定制蛙跳式算法
New algorithms enable drill banks and clamps to move in a 'frog leap' fashion

- **独有异形余料处理** 切角废料单独送出，自动掉落废料箱内，避免砸伤钻坑，无需人工拿取
Unique advantage of Excitech--offcuts are clamped and transported to waste bin without the risks of hitting the bottom drill bank and human intervention.

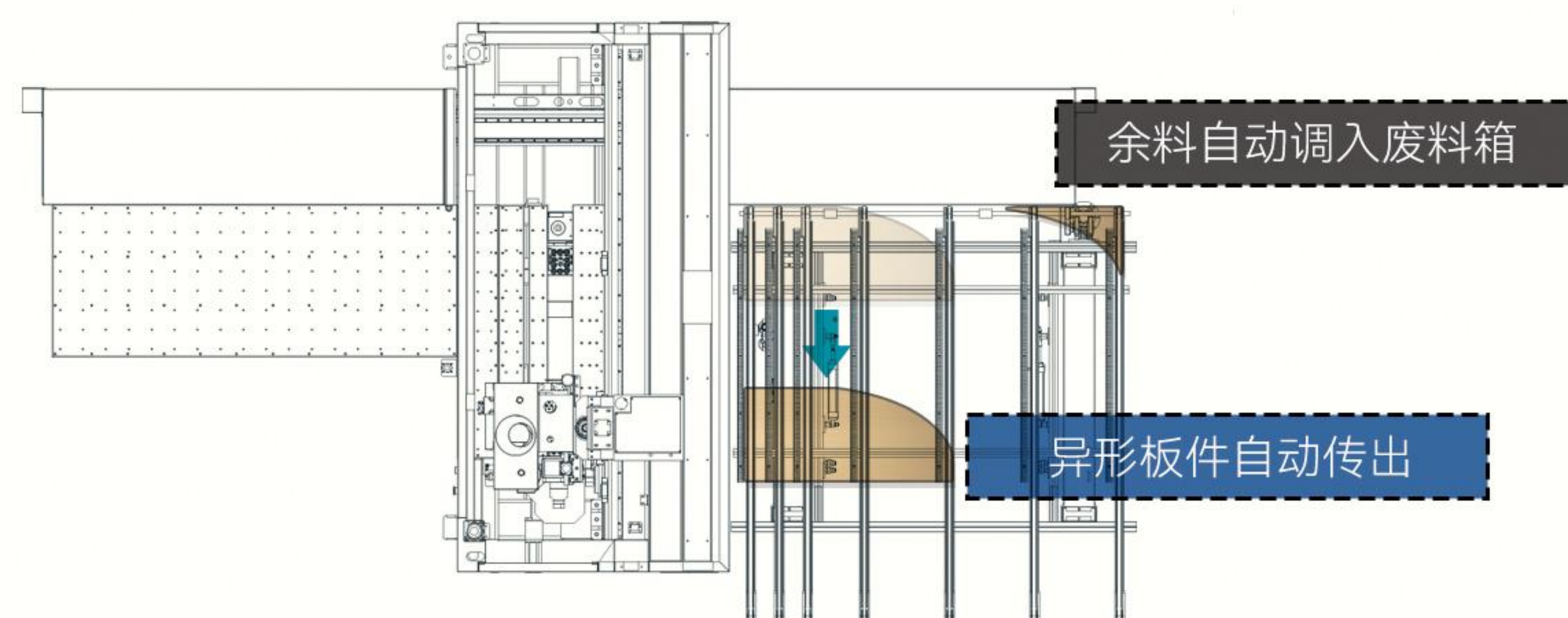

- U形抓手，配合CAM识别可减少换钳频次，提高效率
U shape grippers, optimized CAM algorithm—no residual movements, more efficiency

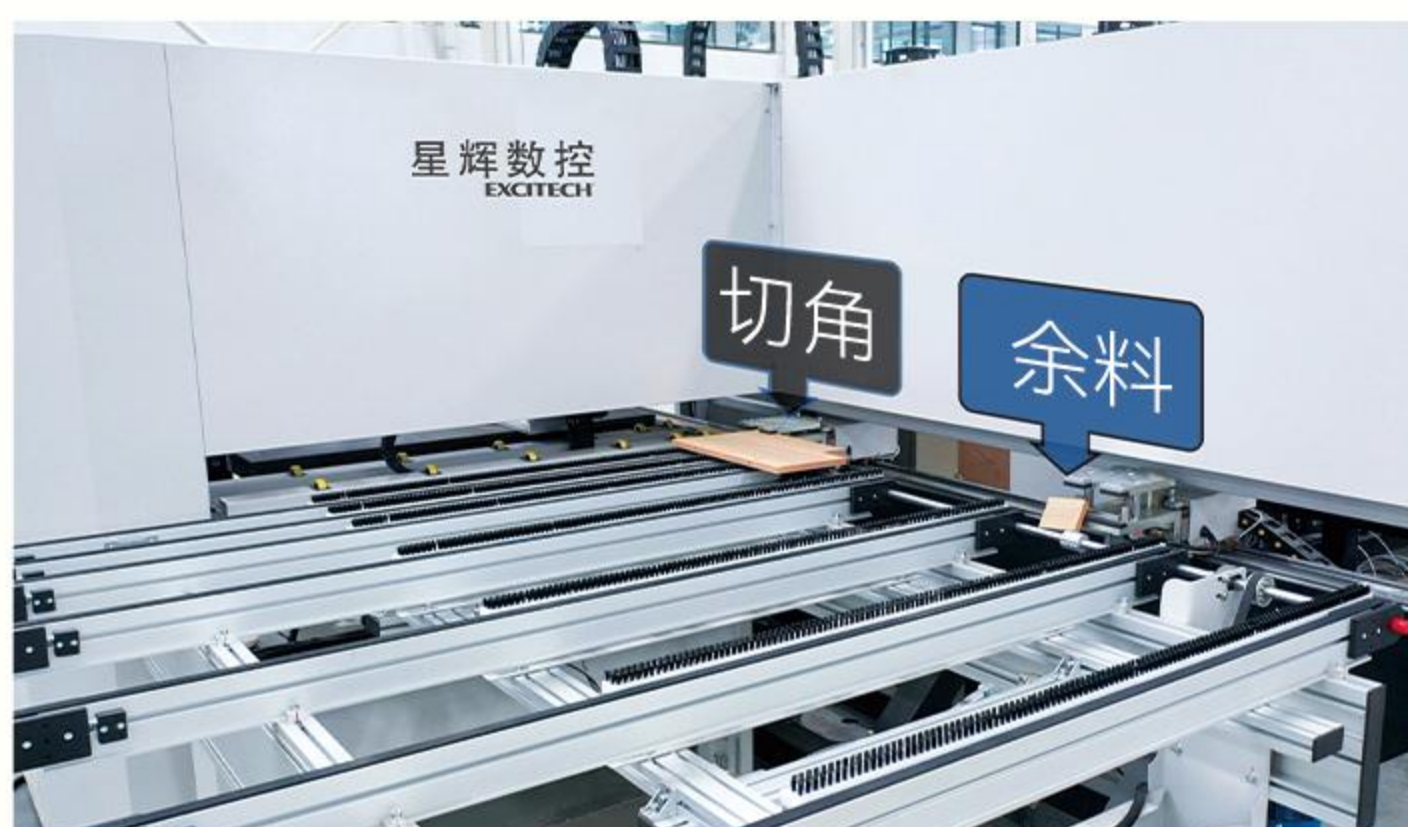

选配滚筒回转线，后出料板材自动回转，提高生产效率

Optional Automated return conveyors

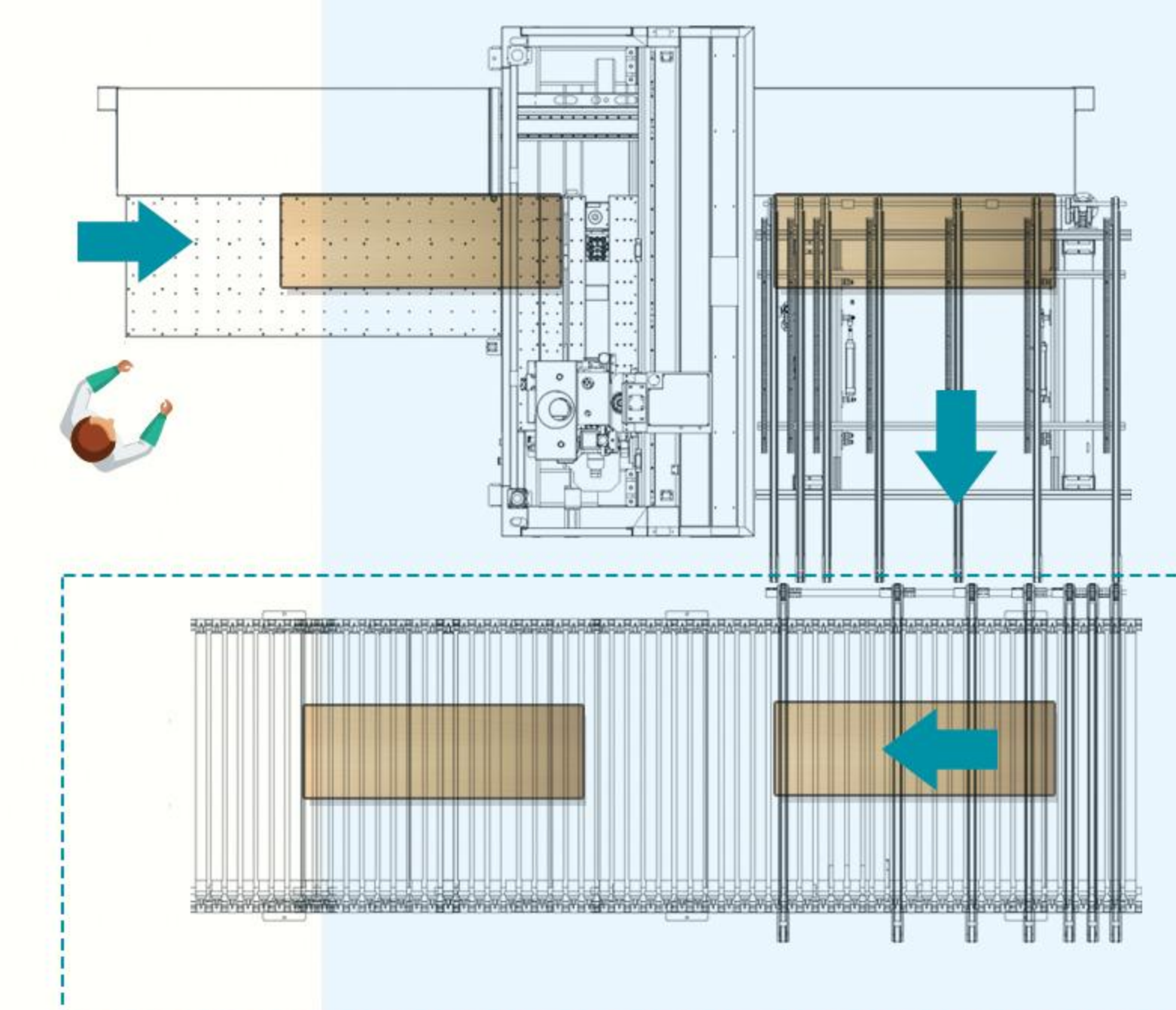

★产品不断升级改良，当外观、配置与参数变更时，均以实物为准

For specific machine configurations, please refer to your technical agreement

系列 Series	有效行程 Traveling Size	最大加工尺寸 Max. Working Size	最小加工尺寸 Min. Working Size	外形尺寸 Dimension	净重 Net. Weight	空行速度 Traveling Speed	钻包配置 Drill Bank Info.	主轴配置 Spindle Info.	台面结构 Table Structure	总功率 Power	吸尘信息 Dust Extraction Info.
EHS-CP 全能六面钻 All Purpose Six Sided Drilling Machine											
全能钻系列	5300x1750x150mm	2800x1200x50mm	70x30x10mm	5900x3400mm	3300kg	130/80/30m/min	垂直钻 10顶+9底+顶板 水平钻 8 Vertical 21+Horizontal 8	6 kW*2 2.2kW*2	气浮台面 +夹钳 Air Table Clamps	26kW	Φ150*3
	EHSW-C自动换刀双钻包六面钻 EHSW-C Six Sided Drilling Machine with Automatic Tool-changers										
5300x1750x150mm	2800x1200x50mm	70x30x10mm	5900x3000mm	3100kg	130/80/30m/min	垂直钻 20顶+9底+顶板 水平钻 16 Vertical 33+Horizontal 16	6 kW*1 3.5kW*1	气浮台面 +夹钳 Air Table Clamps	26kW	Φ150*3	
EHSW 双钻包六面钻 EHSW Six Sided Drilling Machine with Double Drilling Banks											
手动进料	5300x1750x150mm	2800x1200x50mm	70x30x10mm	5900x2600mm	3100kg	130/80/30m/min	垂直钻 20顶+9底+顶板 水平钻 16 Vertical 33+Horizontal 16	3.5kW*2	气浮台面 +夹钳 Air Table Clamps	26kW	Φ150*3
	EHS-E 单钻包-E系列六面钻 EHSW-E Six Sided Drilling Machine										
3000x1400x150mm	2800x1200x60mm	70x30x10mm	3600x2200mm	1600kg	130/80/30m/min	垂直钻 21 (12顶+9底) 水平钻8 Vertical 21+Horizontal 8	3.5kW*2	气浮台面 +夹钳 Air Table Clamps	24kW	Φ150*2	
EHSAW双钻包通过式六面钻 EHSAW Six Sided Drilling Machine											
自动进料	5300x1750x150mm	2800x1200x50mm	200x50x16mm	7300x2600mm	4500kg	130/80/30m/min	垂直钻 20顶+9底+顶板 水平钻 16 Vertical 33+Horizontal 16	3.5kW*2	气浮台面 +夹钳 Air Table Clamps	26kW	Φ150*3
	EHS单钻包六面钻 EHS Six Sided Drilling Machine										
5300x1750x150mm	2800x1200x50mm	70x30x10mm	5900x2600mm	3000kg	130/80/30m/min	垂直钻 10顶+9底+顶板 水平钻 8 Vertical 21+Horizontal 8	3.5kW*2	气浮台面 +夹钳 Air Table Clamps	25kW	Φ150*2	
EHS-2T手动进料双工位六面钻 (四钻包) EHS-2T Double Work-zone Six Sided Drilling Machine											
双工位系列	5300x2630x150mm	2800x1200x50mm	70x30x15mm	5900x3700mm	5000kg	130/80/30m/min	垂直钻 20顶+9底+顶板 水平钻 16 Vertical 33+Horizontal 16	3.5kW*4	气浮台面 +夹钳 Air Table Clamps	35kW	Φ150*4
	EHSA-2T自动进料双工位六面钻 (六钻包) EHSA-2T Double Work-zone Six Sided Drilling Machine										
5300x2630x150mm	2800x1200x50mm	200x50x15mm	7300x3700mm	8000kg	130/80/30m/min	垂直钻 40顶+18底+顶板 水平钻 32 Vertical 66+Horizontal 32	3.5kW*4	气浮台面 +夹钳 Air Table Clamps	35kW	Φ150*6	
E6PTP加工中心 E6 PTP Work Center											
1230	3400x1640x250mm	3060x1240x100mm	320x60 mm	5270x3060mm	3800kg	80m/min	垂直钻 9 水平钻 6 锯片 1	Vertical 9 Horizontal 6 Saw 1	9kW 24000r/min	吸附条 +吸附块 Pods+Rail	22kW Φ150*1
1252	5550x1640x250mm	5200x1260x100mm	320x60 mm	7270x3060mm	6500kg						